

MESSRS.

SPECIFICATION FOR APPROVAL**承 认 书**

Product	DYNAMIC SPEAKER
Part No.	HDK-1808AA-3C15 (RoHS)
Customer	
Customer Part No.	

Approved By	Checked By	Made By
王台平 FEB-28-2018	曹丽萍 FEB-28-2018	LILY FEB-28-2018

常州华龙电子有限公司

DRAGONSTATE ELECTRONIC CORPORATION

中国江苏省常州市新区电子园新四路 36 号

Tel: +86-519-85110078. 86-519-85106698, Fax: +86-519-85101081

EDITION:1.2

1. Specification

HDK-1808AA-3C15 (RoHS)

ITEM		SPECIFICATIONS	
01	Type	Dynamic speaker	
02	Dimension	External diameter 18 mm	
03	Rated Input Power	1.0W	
04	Max. Input Power	1.2W for 1 minute	
05	Impedance	8 ohm \pm 15% at 1500Hz.	
06	Resonance Frequency (Fo)	900Hz \pm 20% at Fo, 1V	
07	Sensitivity (S.P.L.)	89dB(0.1W/0.1m) \pm 3 dB	at AVE 1.0K 1.2K 1.5K 2.0KHz
		96dB (1.0W / 0.1m) \pm 3 dB	
08	Frequency Range	Fo – 20KHz	
09	Total Harmonics Distortion	Max 8 % at 1 KHz, 1.0W.	
10	Voice Coil	Diameter 10.25 mm	
11	Magnet	Rare earth permanent (Nd-Fe-B) magnet Φ 9.7 x 1.3 mm	
12	Weight	2.5g \pm 0.2g	
13	Appearance	Should not exist any obstacle to be harmful to normal operation; damages, cracks, rusts and distortions, etc.	
14	Operation Test	Must be normal at program source – 1.0W	
15	Buzz, Rattle, etc.	Should not be audible at 2.83V sine Wave between Fo to 20KHz	
16	Polarity	When positive voltage is applied to the terminal marked (+), diaphragm should move to the front.	
17	Terminal Strength	Capable of withstand 1kg load for 30 seconds without resulting in any damage or rejection.	
18	Temperature	Operating temperature: -20 $^{\circ}$ C to +60 $^{\circ}$ C	
		Storage temperature: -30 $^{\circ}$ C to +70 $^{\circ}$ C	

2-1. Test Condition

Standard

Temperature : 15 ~ 35°C

Relative humidity : 25% ~ 85%,

Atmospheric pressure : 860mbar to 1060mbar.

Basic

Temperature : 20±3°C

Relative humidity : 60% ~ 70%,

Atmospheric pressure : 860mbar to 1060mbar

2-2. Standard Test Fixture

1. Input Power : 1.0W (2.83V)

2. Zero Level : -dB

3. Mode : SPEAKER

4. potentiometer Range : 50dB

5. Sweep Time : 0.5sec

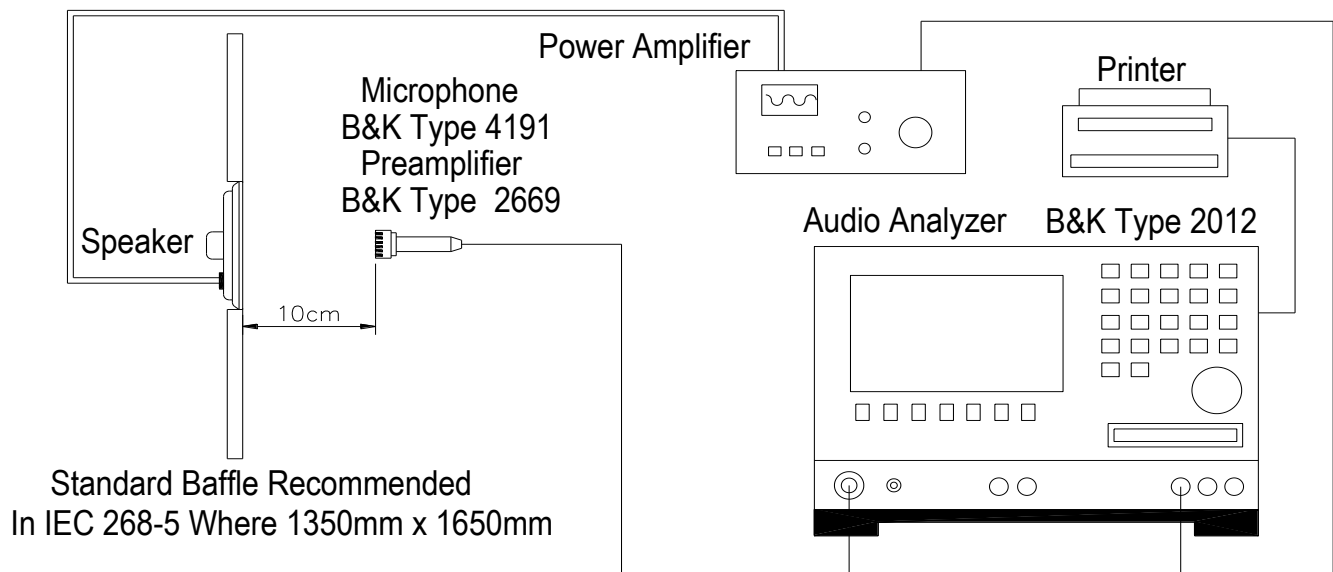

2-3.Frequency Response Curve

X:1.5000kHz *Y:92.69dB ZA:Live Curve SSR Fund.

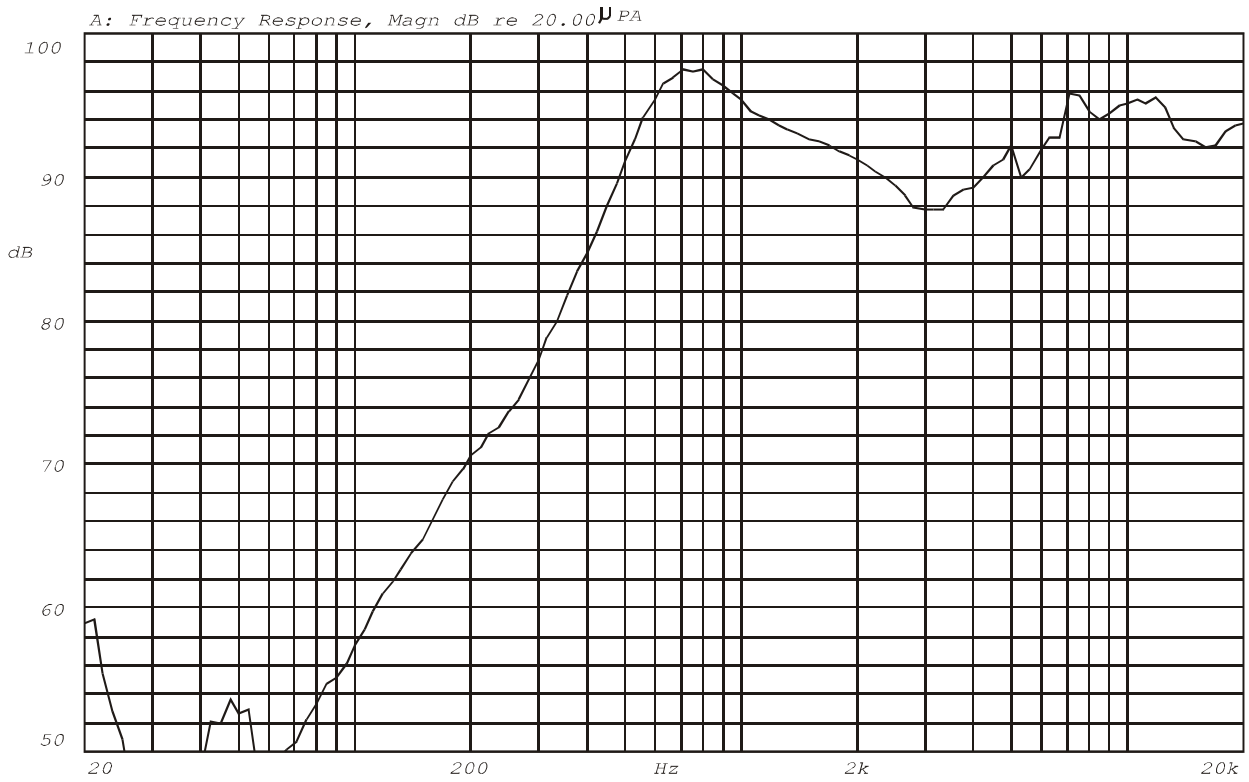

Mode: SSR



3.Dimension

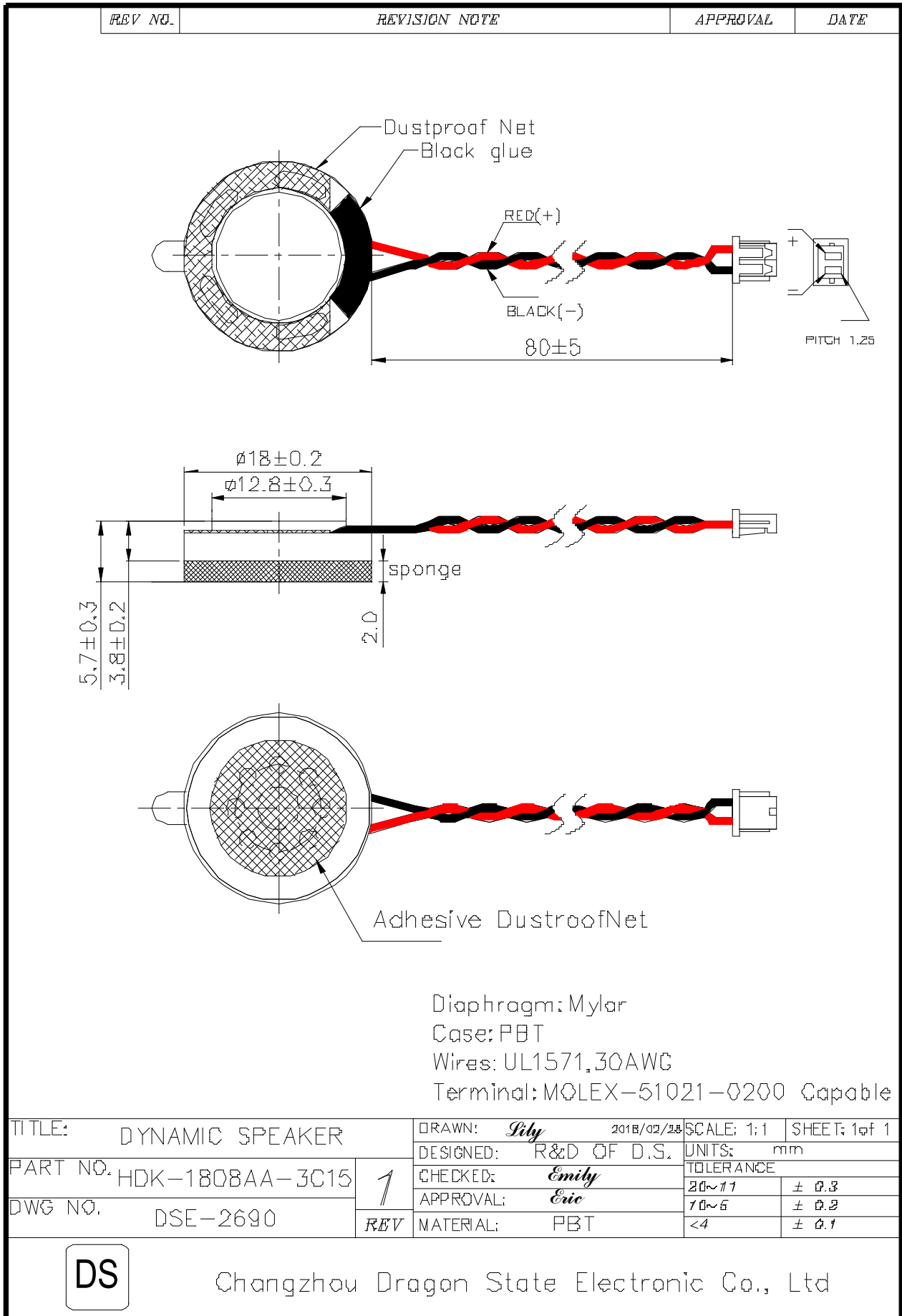

4. Reliability Tests

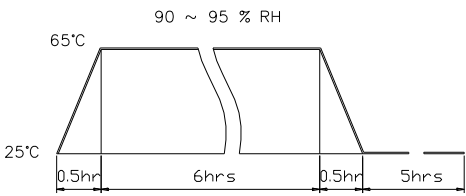
Items.		Specifications
01	High temp. Test	Keep 96 hours at $+70^{\circ}\text{C} \pm 3^{\circ}\text{C}$ and leave 3 hours in normal temperature and then check
02	Low temp. Test	Keep 96 hours at $-30^{\circ}\text{C} \pm 3^{\circ}\text{C}$ and leave 3 hours in normal temperature and then check
03	Humidity test	Keep 96 hours at $+60^{\circ}\text{C} \pm 3^{\circ}\text{C}$ relative humidity 95% and leave 3 hours in normal temperature and then checked.
04	Temp./Humidity cycle	<p>The part shall be subjected 5 cycles. One cycle shall be 12 hours and consist of;</p> 
05	Thermal cycle test.	Low temperature: $-30^{\circ}\text{C} \pm 3^{\circ}\text{C}$, temperature: $+70^{\circ}\text{C} \pm 3^{\circ}\text{C}$, cycle: 1 hour/cycle each, and then keep 5 cycles in a room.
06	Vibration	10~200~10Hz sin-wave sweep 15min. 5G(constant) X,Y, Z 3 direction. 2 hours each, total 6 hours.
07	Fix drop test	Fix on jig. Then drop from 152cm height to the concrete floor X, y, z 6 direction. 5 times each, total 30 times.
08	Free drop test	Free drop from 100cm height to the concrete floor X, y, z 6 direction. 1 times each, total 6 times.
09	Rated Power test	Rated Power white noise is applied for 96 hours
10	Max Power test	Max power 1 min on – 2 min off 10 cycles.
11	Terminal strength test	Capable of withstand 1kg load for 30 seconds without resulting in any damage or rejection.
<p>Criterion: After these test , the change of S.P.L shall be within ± 3 dB .</p>		

SOLDERING CONDITION

Recommend using constant branding iron in **15 ~ 30W**, and in temperature range **$350 \pm 10^{\circ}\text{C}$** .

Soldering time not over **3** seconds.

5.Packing

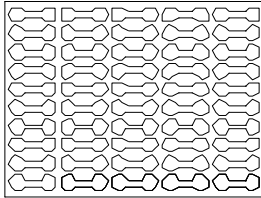
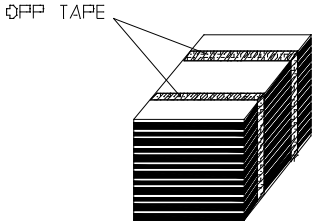
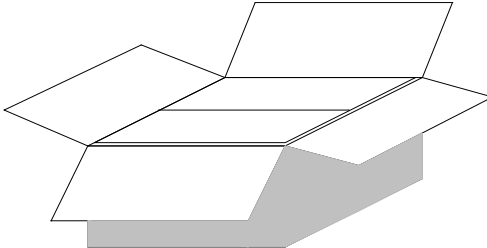
REV NO.	REVISION NOTE	APPROVAL	DATE
	 <p>Cover(325*245*5mm) Material: Paper</p>		
	 <p>Box(325*245*13mm) 100 pcs Material: Paper+Epe</p>		
	 <p>Middle(325*245*155mm) 1000 pcs(10*100 pcs) Material: Paper+Epe</p>		
	 <p>Outer Box(490*360*350mm) 4000 pcs(4*1000 pcs) Material: Paper</p>		
单位: mm			
TITLE: packing		DRAWN: Lily 2015/08/25	SCALE: 2:1 SHEET: 1 of 1
PART NO.		DESIGNED: R&D OF D.S.	UNITS: 77872
DWG NO.		CHECKED: Emily	TOLERANCE
		APPROVAL: Eric	20~11 ± 0.3
REV 1		MATERIAL: ***	10~5 ± 0.2
			<4 ± 0.1
<div style="display: flex; align-items: center;"> <div style="border: 1px solid black; padding: 2px 5px; margin-right: 10px;">DS</div> Changzhou Dragon State Electronic Co., Ltd </div>			